

5006# SSD15-150 伺服鑽孔/攻牙動力頭(專利號碼：M446677) Drilling/Tapping Spindle Head-Servo Type (Patent No. M446677)

規格	Model	SSD15	SSD15H
鑽孔能力	Drilling Capacity(S45C)	φ 50	
最大行程	Max. Stroke	150mm	
最高轉速	Max. RPM	1600	4000
馬力	Horsepower	5HP×4P	
主軸皮帶輪	Spindle Pulley	8M-62T, φ 156.5×J×25	
主軸軸承	Spindle Bearing	6014Z×1 / 6012Z×1 32014×1 / 32012×1	7014×2 7012×2
皮帶輪軸承	Pulley Bearing	6213ZZ×2	
螺桿軸承座軸承	Bearing Of Ballscrew Bearing Block	7205×2	
螺桿軸承座油封	Seal Of Ballscrew Bearing Block	TC30-50-10×2	
前蓋油封	Front Cover Seal	TC150-180-14×1	
主軸油封	Spindle Seal	TC90-110-12×1	
滾珠螺桿	Ball screw	φ 32×5×C5	

Roundness: ≤ 0.003mm

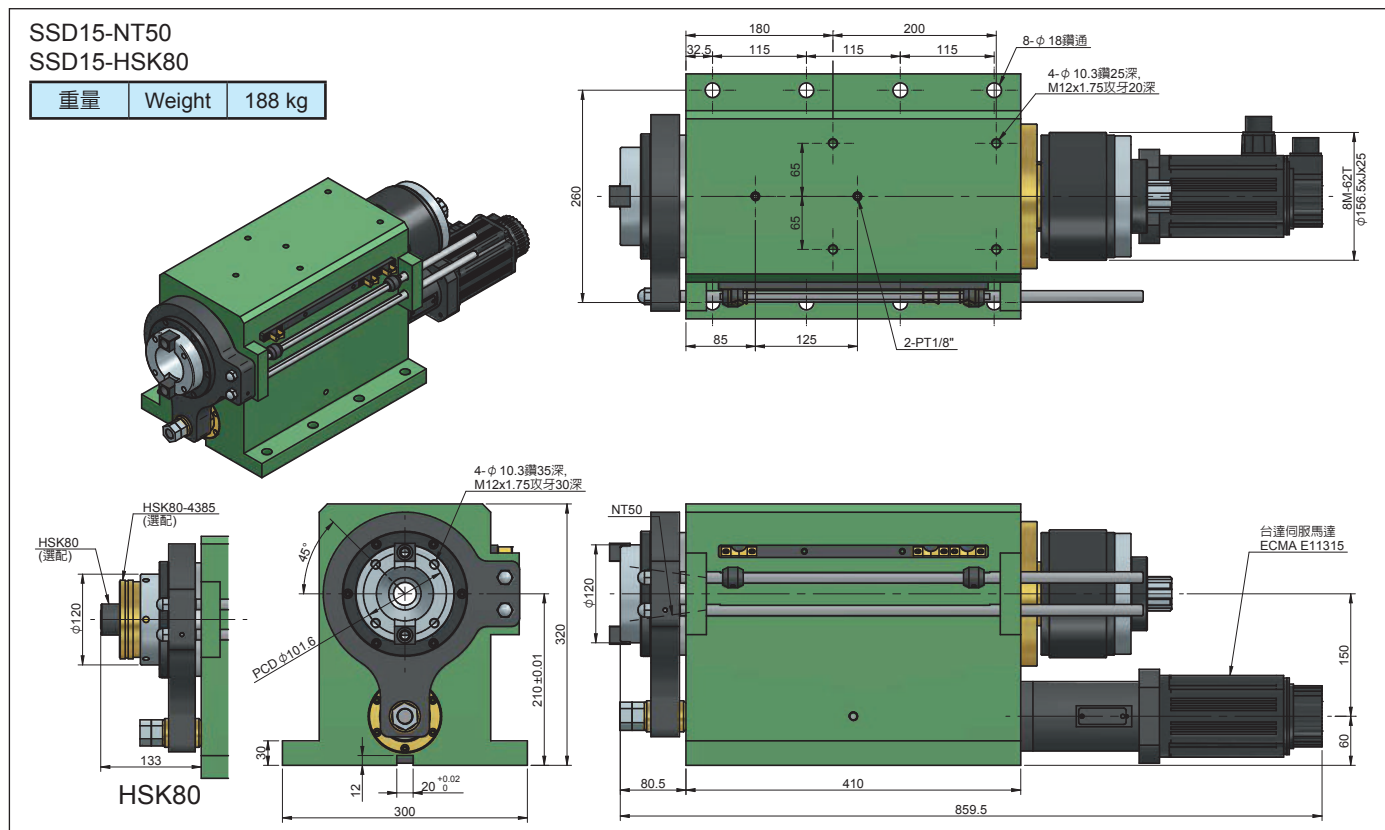

5006# SSD15-150 伺服鑽孔/攻牙動力頭 (專利號碼：M446677) Drilling/Tapping Spindle Head-Servo Type (Patent No. M446677)

SSD15-NT50-MF
SSD15-HSK80-MF

重量	Weight	240 kg
----	--------	--------

台灣精品
TAIWAN EXCELLENCE
2017

SSD15-NT50-MB
SSD15-HSK80-MB

重量	Weight	240 kg
----	--------	--------

台灣精品
TAIWAN EXCELLENCE
2017